



USE AND MAINTENANCE INSTRUCTIONS

WOOD STOVE

Nadia

Noemi

Read instructions carefully before installation, use and maintenance
The instruction manual is an integral part of the product

Laminox S.r.l. reserves the right to change the characteristics and data reported in the following document at any time and without warning in order to improve their products. This manual, therefore, cannot be considered as a contract with third parties.

The updated manuals and drawings are available on the website www.laminox.com.

Dear Customer, thank you for choosing one of our products, which is a result of technological expertise and our continuous quest for superior products in terms of safety, reliability and performance. This manual contains all the information and helpful tips for using your product with maximum safety and efficiency.

IMPORTANT INFORMATION

This manual has been prepared by the manufacturer and is an integral and essential part of the product. In the event of sale or transfer of the product, always ensure the presence of the manual as the information it contains is addressed to the buyer and to all those various people involved in the installation, use and maintenance of the product. Carefully read the instructions and information contained in this manual before installation, operation and maintenance of the product. The instructions contained in this instruction manual guarantee the safety of persons and property and ensure efficient operation and a longer service life. The manufacturer declines all responsibility for damage caused by failure to observe instructions regarding installation, use and maintenance listed in the instruction manual, for unauthorized modifications or non-original replacement parts. Product installation and use must be carried out in accordance with the manufacturer's instructions and in compliance with European, national and local regulations. Installation, electrical connection, functional testing, maintenance and repairs are operations that must be performed by qualified and licensed personnel who must have appropriate knowledge of the product. Product installation must not be carried out close to walls made of wood or combustible material. For proper installation, you must observe the "Safety distances" section. Verify the exact flatness of the floor where you will install the product. When handling the steel parts of the cladding, use clean cotton gloves to prevent leaving fingerprints difficult to remove for the first cleaning. Stove installation must be performed by at least two people. Connect the stove to the mains only after proper professional connection to the chimney flue. The power cable plug must remain accessible after installation of the stove. Only operate the stove with regulation wood pellets (refer to the "FUEL" chapter). Never use liquid fuels to operate the pellet stove or to stoke the embers present. Provide adequate ventilation in the installation area during operation. In the presence of operation failures, fuel supply will be interrupted. Re-start the unit after removing the cause of the failure. Discontinue use of the product in the event of failure or malfunction. Do not remove the safety guard located in the pellet tank. Any accumulated unburned pellets in the burner as a result of repeated failed ignitions must be removed prior to ignition. Pellet stove operation can cause very hot heating of the handles, the chimney flue and glass surfaces. Only touch these parts during operation when wearing protective clothing or with adequate aids. Because of the creation of heat on the glass, make sure that no persons unfamiliar with stove operation stand in the installation area. Inform children of the precautions to be observed during product operation and of possible dangers. In the event of problems or misunderstanding of the instruction manual, contact the dealer. Placing objects which cannot withstand heat on the stove or within the minimum required safety range is prohibited. Do not open the door during operation or operate the stove with its glass broken. For product terms, limitations and exclusions, please refer to the warranty included with the product. In order to pursue a policy of constant product development and renewal, the manufacturer may make changes to it as deems appropriate without notice. This document is the property of the manufacturer and cannot be disclosed in whole or in part to any third party without the written consent of the company, which reserves all rights according to the law.

DIRECTIVES AND REGULATIONS

This product has been designed in accordance with the EN 14785:2006 standard and also complies with the following directives:

2009/125/EC (Ecodesign)

2014/35/EU (LMV - Low Voltage directive)

2014 30/EU (EMC – Electromagnetic Compatibility)

1	INSTALLATION.....	4
1.1	General notes.....	4
1.2	Smoke discharge system	4
1.3	Smoke duct	4
1.4	Chimney of flue	5
1.5	Using an external fume duct.....	6
1.6	Chimney pot.....	7
1.7	External air intake vent.....	8
1.8	Installation room.....	9
1.9	Minimum safety distances	10
1.10	Flooring protection	11
1.11	Passing through combustible materials	11
2	SPECIFICATIONS AND TECHNICAL DATA.....	12
2.1	Technical data.....	12
2.2	Product identification data	12
2.3	Electrical diagram.....	12
3	FUEL	13
3.1	General notes.....	13
4	ASSEMBLY	13
4.1	General notes.....	13
4.2	Unpacking	13
5	USE	14
5.1	Ignition	15
5.2	Normal operation.....	15
5.3	Ventilation (only suitable models).....	16
6	WARNING AND MAINTENANCE	17
6.1	Opening the door	17
6.2	Combustion chamber cleaning	17
6.3	Smoke chamber cleaning	17
6.4	Exhaust system cleaning.....	17
6.5	Cleaning metal and ceramic parts	17
6.6	Cleaning glass.....	17
6.7	Broken glass	17
6.8	Stove inactivity	18
6.9	Routine and special maintenance.....	18

1 INSTALLATION

1.1 General notes

The heating system or appliance must be installed in order not to damage the building and other systems. The installer must strictly comply with standard UNI 10683:2022 and all other applicable local regulations.

1.2 Smoke discharge system

Every device must be connected to a fume discharge system, which ensures dispersion of combustion products into the atmosphere.

The fume discharge system must meet the following requirements:

- The combustion products must be discharged from the roofs. Direct wall discharge or towards closed spaces, even in open air, is prohibited.
- The components must be made of material with A1 fire reaction class. In particular, the use of metal extendible and flexible hoses is prohibited.
- It must be ensured that the duct is completely sealed and correctly installed
- Construction of the exhaust duct must be done by specialised personnel or companies, as reported in the following manual. Always create the exhaust system so that periodic cleaning is assured without having to dismantle any parts.
- The installation of dampers or valves which may obstruct the passage of exhaust fumes is **prohibited**.
- Installation in a chimney flue where exhausted fumes or vapours from other equipment (boilers, hoods, etc.) is **prohibited**.
- It should not be connected to any other fireplace, stove, boiler, or hood of any kind (Fig. 1).

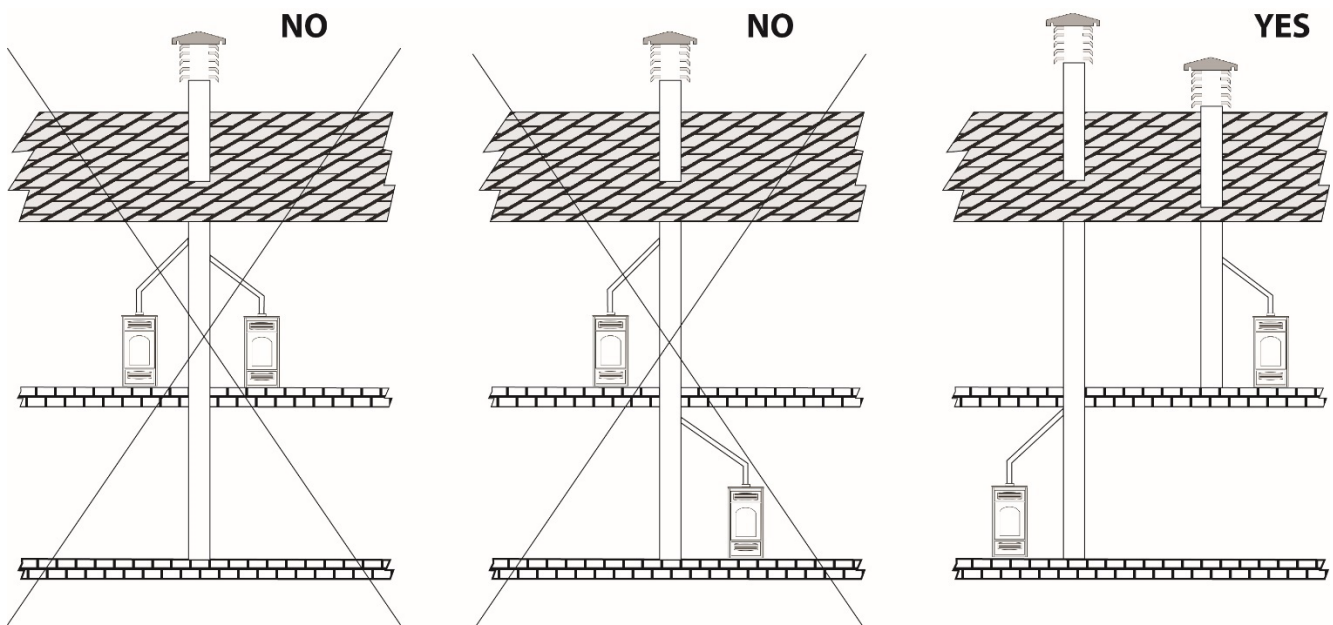

Fig.1

1.3 Smoke duct

The smoke duct is the pipe that connects the appliance to the Chimney

The smoke ducts must be installed in compliance with the following general requirements:

- If they pass inside unheated rooms or outside, they must always be insulated so as to have thermal resistance R not less than $0.12 \text{ m}^2\text{K/W}$.
- They must not pass through rooms in which the installation of combustion appliances is forbidden
- They must not pass through rooms at risk of fire or rooms that cannot be inspected

- They must be installed in such a way as to allow for normal thermal expansion
- Along their entire length, they must have a diameter no less than that of the attachment of the appliance's evacuation duct
- They must allow the recovery of soot and be inspectable
- They must be equipped with an element with a sampling hole in accordance with UNI 10389-2
- The use of flexible metal pipes to connect the appliance to the chimney is not permitted

1.4 Chimney of flue

Each appliance must have its own flue with the following characteristics:

- Must have a section equal to or greater than the diameter of the fume exhaust pipe of the stove and a height no less than the one stated (*see table 1*)
- Must operate in negative pressure
- The internal section must be uniform, preferably circular: the square or rectangular sections must have rounded corners with a radius of no less than 20 mm, maximum ratio between the sides of 1.5, walls as smooth as possible and without restrictions, curves must be regular and seamless, deviations from the axis no greater than 45° (*Fig. 2*).
- It must not have more than two changes of direction with slopes not exceeding 45°
- It must be used exclusively for the evacuation of combustion products
- It must have a mainly vertical course and be free from any bottleneck along their entire length
- It must have a draft that complies with the indications in the product's **technical data sheet**
- It must be properly spaced from combustible or flammable materials through an air gap or suitable insulating material.
- Creating fixed or mobile apertures on the chimney flue to connect equipment other than auxiliary devices is prohibited.
- Passing other air supply channels and piping for utilities through the chimney flue, however large, is prohibited.
- The chimney flue should be equipped with a collection chamber for solid materials and any condensate, located below the mouth of the flue, so as to be easily opened and inspected from an airtight door.
- Whenever using parallel output chimneys, it is advisable to raise a bracing element. (*Fig. 6*)

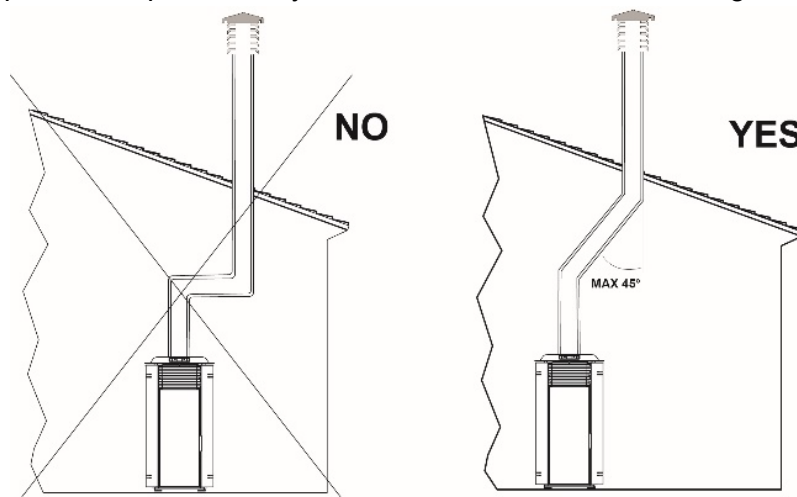

Fig.2

The chimney draft must be at least 6 Pa

If the draft exceeds 15 Pa it is necessary to reduce it by installing a draft control

1.4.1 Maximum usable lengths

Painted aluminised steel tubes (minimum thickness 1.5 mm), stainless steel tubes (Aisi 316) or porcelain tubes (minimum thickness 0.5 mm) with a nominal diameter of **130 mm** can be used.

The male-female connection collars must be at least 50 mm long.

TYPE OF SYSTEM	WITH Ø 80 mm TUBE
Minimum length	3 m
Maximum length (with 3 90° curves)	8 m
Maximum number of curves	2

Tab.1

NOTE: load losses of a 90° curve can be equated with those of 1 metre of tube; the serviceable T-connection is to be considered as a 90° curve.

1.4.2 Using an existing chimney flue

If you wish to use an already existing chimney flue, it is advisable to have it checked by a professional chimney sweep to ensure that it is watertight. This is because fumes, being slightly pressurised, could infiltrate cracks in the chimney flue and invade living spaces. If an inspection finds that the chimney flue is not perfectly intact, it is advisable to intubate it with new material. If the existing chimney is large, we recommend inserting a tube with a maximum diameter of 150 mm. It is also advisable to insulate the fume exhaust duct. Figs. 3 and 44 demonstrate the solutions to adopt if you want to use an existing chimney flue.

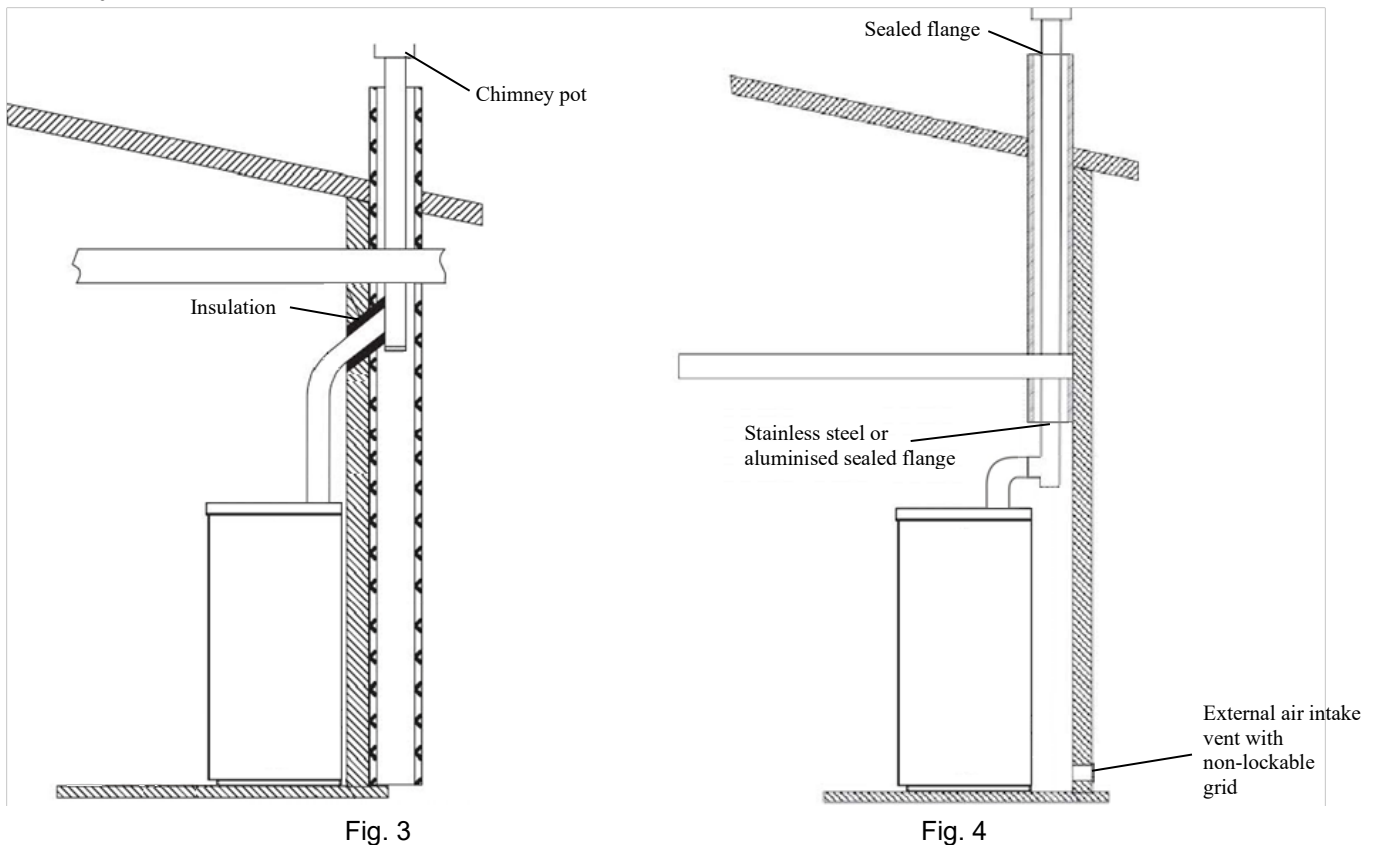

1.5 Using an external fume duct

An external fume duct can be used only if it meets the following requirements:

- Only insulated tubes (**double wall**) in stainless steel, secured to the building (*Fig.5*) should be used.
- An inspection area should be created at the base of the duct for performing periodic checks and maintenance.
- It should be equipped with a windproof chimney pot and observe the distance "d" from the ridge of the building as described in par. 1.6.

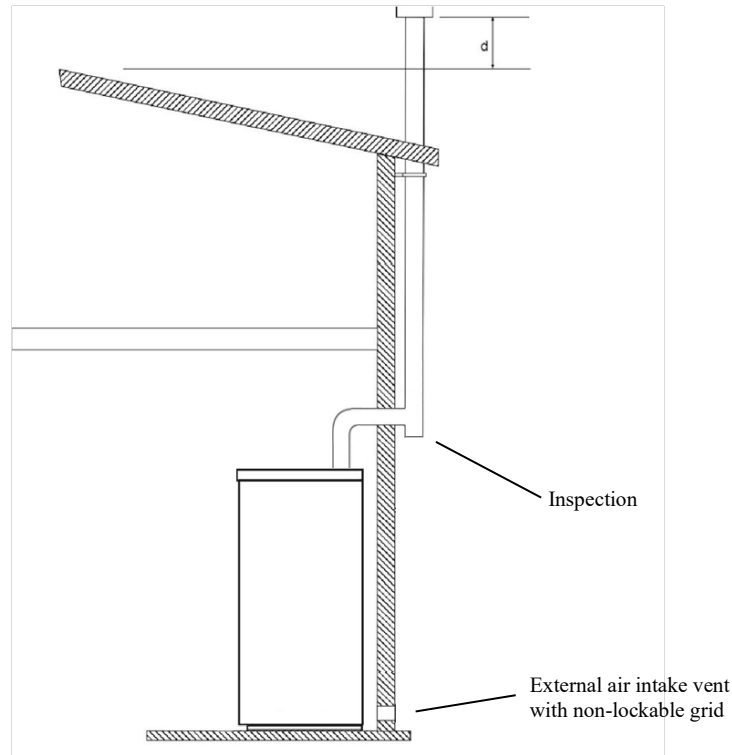

Fig. 5

1.6 Chimney pot

The top of the chimney flue must be equipped with a device, called a chimney pot, which facilitates dispersion into the atmosphere of combustion products.

The chimney pot must meet the following requirements:

- Its internal section and shape must be equivalent to that of the chimney flue.
- Have a useful outlet section no less than double that of the chimney flue.
- Chimney pots that emerge from the roof or which remain in contact with the outside (for example in the case of an open loft), must be covered with brick elements and well isolated. It must be constructed so as to prevent penetration into the flue of rain, snow, or foreign bodies and so that, in the event of winds in any direction and at any angle, it assures the discharge of combustion products (windproof chimney pot).
- The chimney pot must be positioned so as to guarantee an adequate dispersion and dilution of combustion products and, in any case, outside the zone of reflux. This zone can be different sizes and shapes depending on the angle of slope of the roof, so it is necessary to adopt the minimum heights shown in *Fig.7* and *Fig.8*.
- The chimney pot must be of windproof and exceed the height of the ridge, (*Fig.7* and *Fig.8*).
- Any buildings or other obstacles that exceed the height of the chimney pot must not be close to the chimney pot itself (*Fig.7*).

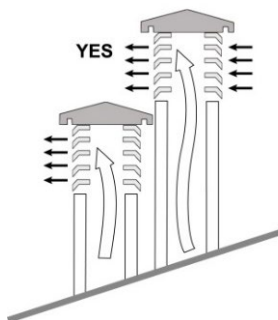

Fig.6

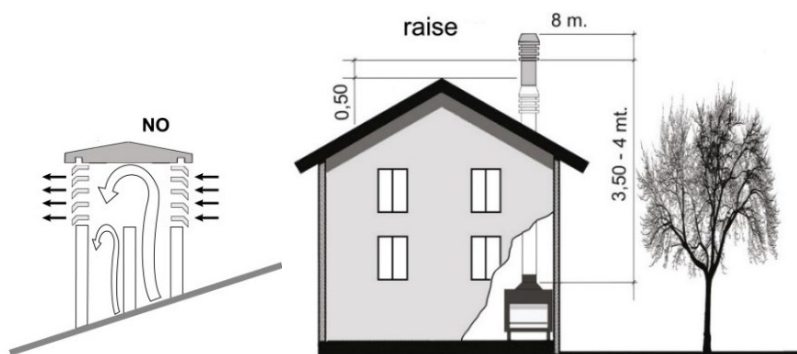

Fig.7

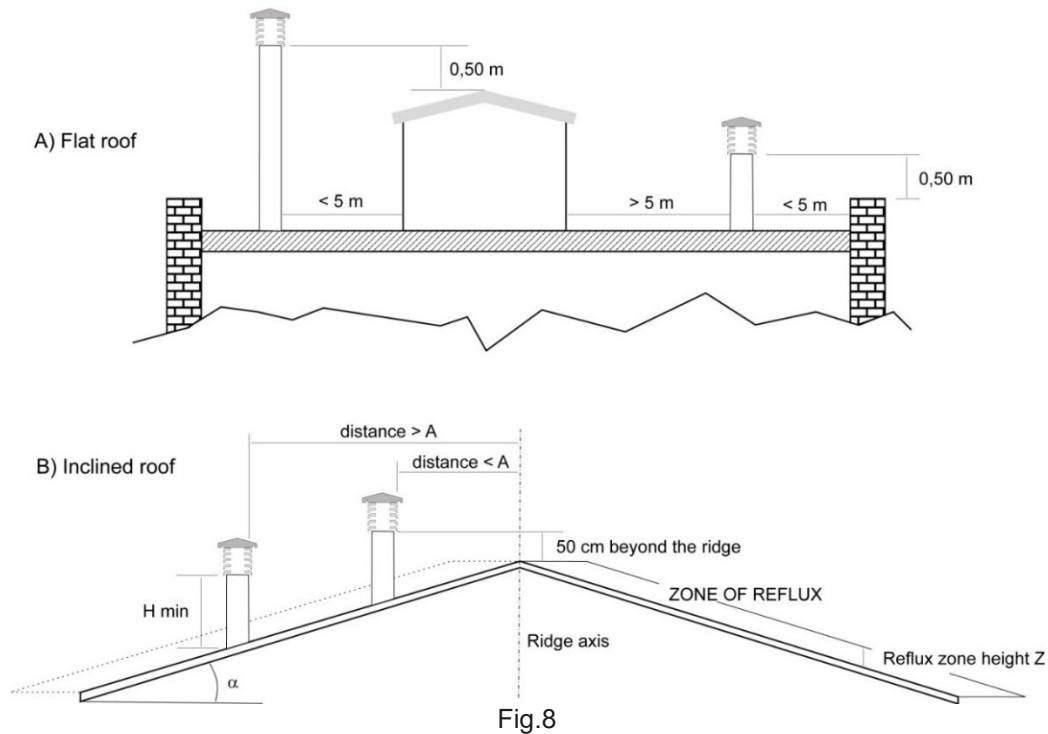

Fig.8

1.7 External air intake vent

The stove must have the air necessary to ensure smooth combustion operation and good environmental well-being.

Make sure that the room where the stove is installed offers sufficient ventilation and install an air supply duct from the outside with the recommended minimum section of **100 cm²**.

Ventilation openings are not required:

- In the case of an airtight installation
- If the room has permanent permeability to external air which ensures that under any conditions a depression greater than -4 Pa does not occur

Ventilation opening:

- They must be positioned close to the floor
- They must be made so as to make maintenance operations possible
- They must be protected by grids, metallic nets, etc., without reducing their net useful section

In the case of a closable vent, this must be:

- Normally open
- Open automatically when the appliance is turned on

1.7.1 Direct Vent

Direct ventilation must be achieved via ventilation openings directly in the installation room of the appliances

1.7.2 Indirect vent

Air flow can also be obtained from a room adjacent to the installation room, provided that this flow can be carried out freely through permanent, non-closable openings communicating with the outside.

In case of passage through several rooms, the net section of the ventilation opening must be doubled at each passage

With respect to the installation room, the adjacent room should not be put under vacuum with respect to the external environment as a result of a reverse draft caused by the presence in this space of another utility device or suction device. The room adjacent to the permanent openings must meet the

requirements set out in the paragraphs above. The adjacent room cannot be used as a garage, for storage of combustible material or for activities involving a risk of fire

1.8 Installation room

- Installing the device inside rooms at risk of fire is prohibited.
- **Outdoor installation** in locations exposed to weathering or humid areas **is prohibited**.
- In bathrooms, bedrooms and studios can be installed only airtight appliances with external ducted combustion air intake.
- Stove installation must be carried out in a location which allows safe and easy use and simple maintenance. Said location must also be equipped with electrical grounding as required by law.

1.8.1 Preventing house fires

- The installation room must not be at risk of fire or used as a warehouse for combustible material. The storage of solid fuel for a maximum volume of 1.5 m³ is permitted in the room where the appliance is installed
- The fireplace connecting tube must never pass through a combustible surface
- It is also advisable to maintain all combustible elements or flammable material such as beams, wooden furniture, curtains, flammable liquids, etc. outside the radiation area of the furnace and at a distance of at least 1 m from the heating block.
- In the event that the surrounding space has coverings in combustible or heat-sensitive material, a protective membrane made of non-combustible insulating material must be interposed. If the flooring is made of combustible material, a non-combustible protective material that protrudes laterally and frontally from 15 cm to 30 cm must be provided at the mouth of the furnace.

For further information, refer to local requirements.

CAUTION: when a fume exhaust pipe passes through a wall or ceiling, particular installation methods must be applied (protection, thermal insulation, distances from heat sensitive materials, etc.).

1.8.3 Installation in presence of several appliances

The following table shows the possible installation configurations of several appliances in the same room or in adjoining rooms

	Biomass appliance with non-airtight installation	Biomass appliance with airtight installation	Type A Gas appliance	Type B Gas appliance	Type C Gas appliance	Gas cooking appliances
Biomass appliance with non-airtight installation	Admitted in compliance with UNI 10683	Allowed	Forbidden	Forbidden	Allowed	Allowed
Biomass appliance with airtight installation*	Allowed	Allowed	Allowed	Allowed	Allowed	Allowed

Tab.2

** An airtight installation does not consume the oxygen of the room by taking all the air from outside (if suitably ducted) and allows the product to be installed inside all houses that require a high degree of insulation such as "passive houses". Thanks to this technology there is no risk of smoke emissions into the room and there is no need for air intakes in the installation room.*

1.8.4 Minimum volume of the installation room

To calculate the minimum volume of the installation room, the formula

Room Volume = 10 x Appliance Power must be used

Room Volume is expressed in m³ and Appliance Power is expressed in kW and is equal to the minimum power of the machine

1.8.5 Capacity of the floors of the installation room

The floor of the installation room must have a capacity suitable for supporting the total weight of the appliance

1.9 Minimum safety distances

The following figures show the minimum safety distances which must always be guaranteed.

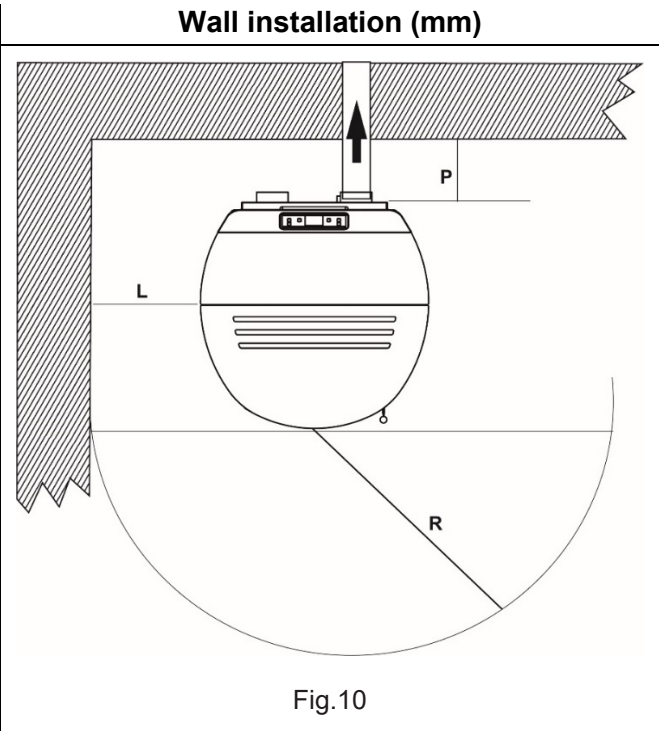
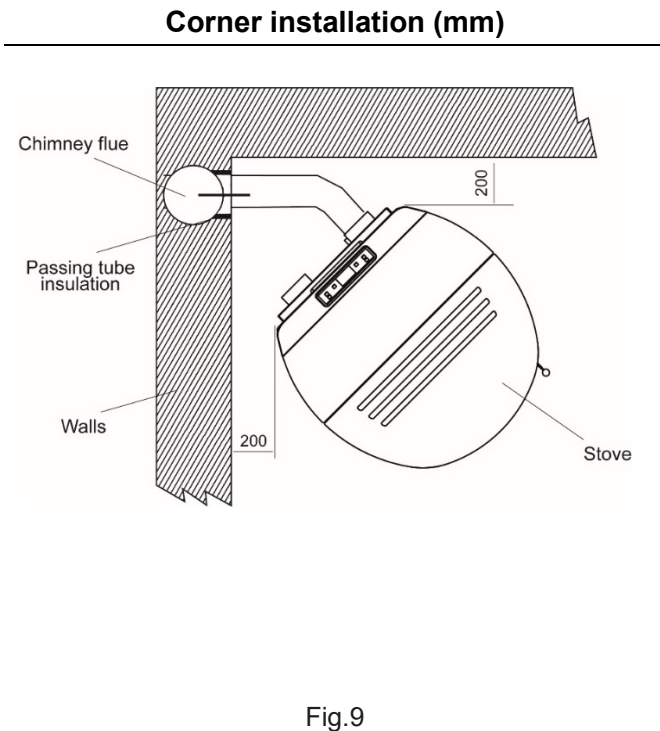

Safety distances from flammable material

- Minimum distance in air from the flammable rear wall
- Minimum distance in air from the flammable side wall
- Frontal distance from flammable material

- P** = 200 mm
- L** = 200 mm
- R** = 1500 mm

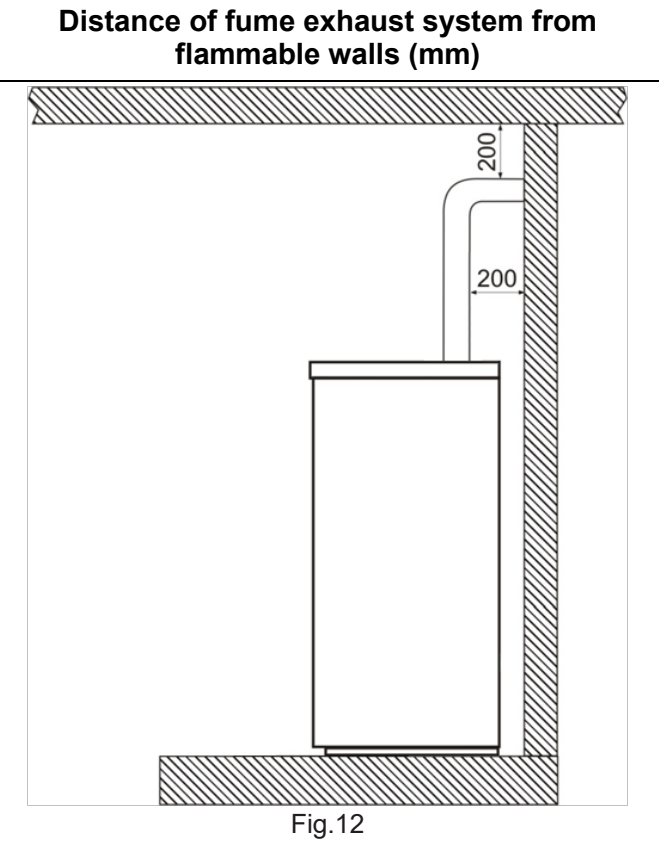
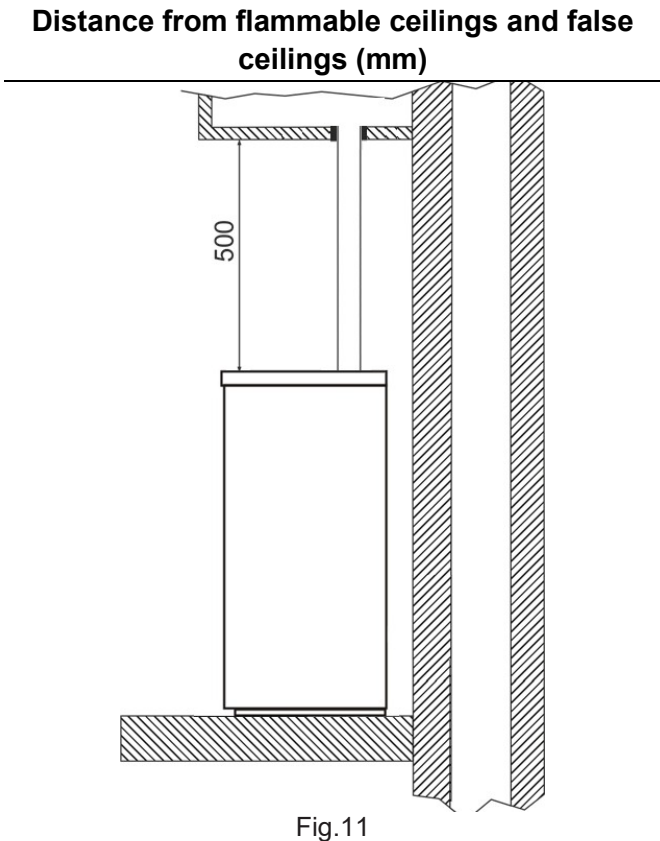

1.10 Flooring protection

In the event of valuable flooring or flooring that is sensitive to heat, moisture or is flammable, a floor protection must be used (i.e. sheet steel, marble or tile slabs).

Whichever type of protection selected, it must protrude at least 300 mm from the front, at least 150 mm from the sides of the stove, must withstand the weight of the stove and have a thickness of at least 2 mm (Fig. 13 and 14).

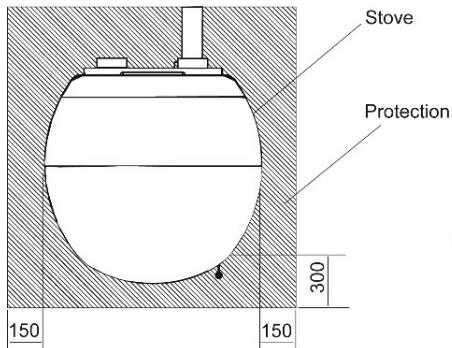

Fig. 13

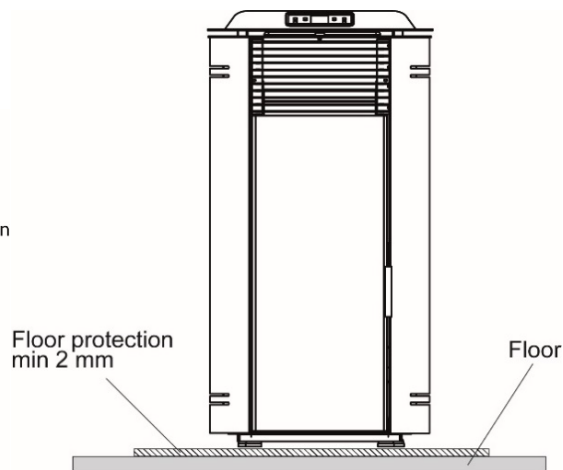

Fig. 14

1.11 Passing through combustible materials

Once the location of the stove has been decided, you will have to drill the hole for passage of the fume exhaust tube. This varies depending on the type of installation (therefore on the exhaust tube diameter) and on the type of wall or roof to be crossed (table 3).

The insulator must be of mineral origin (rock wool, ceramic fibre) with a nominal density greater than 80 kg/m³.

	Insulation thickness [mm]	Fume exhaust tube diameter [mm]
		Ø130
		Diameter of holes to be created [mm]
Wooden wall, or wall which is flammable or has flammable parts	100	330
Concrete wall or roof	50	23
Brick wall or roof	30	190

Tab.3

2 SPECIFICATIONS AND TECHNICAL DATA

2.1 Technical data

Model	Nadia	Noemi
<i>Global thermal power</i>	8,2 kW	8,2 kW
<i>Hourly consumption</i>	1,9 kg/h	1,9 kg/h
<i>Rated thermal power</i>	7,0 kW	7,0 kW
<i>Efficiency</i>	85,4 %	85,4 %
<i>Recommended draft</i>	10 Pa	10 Pa
<i>Smoke outlet diameter</i>	120 mm	120 mm
<i>Weight</i>	89 kg	80 kg
<i>Door (LxH)</i>	210x290 mm	210x290 mm
<i>Combustion chamber (LxPxH)</i>	210x320x290 mm	210x320x290 mm
<i>Dimensions (LxPxH)</i>	572x536x1088 mm	446x504x1052 mm

2.2 Product identification data

The technical label shows device data and performance. Tampering with, removing or lack of a technical label makes installation and maintenance operations difficult, due to the lack of product identification. In the event of damage, request a duplicate from our service centre. Given the importance of the data label, we recommend installing the stove at a distance at which it is always visible.

2.3 Electrical diagram

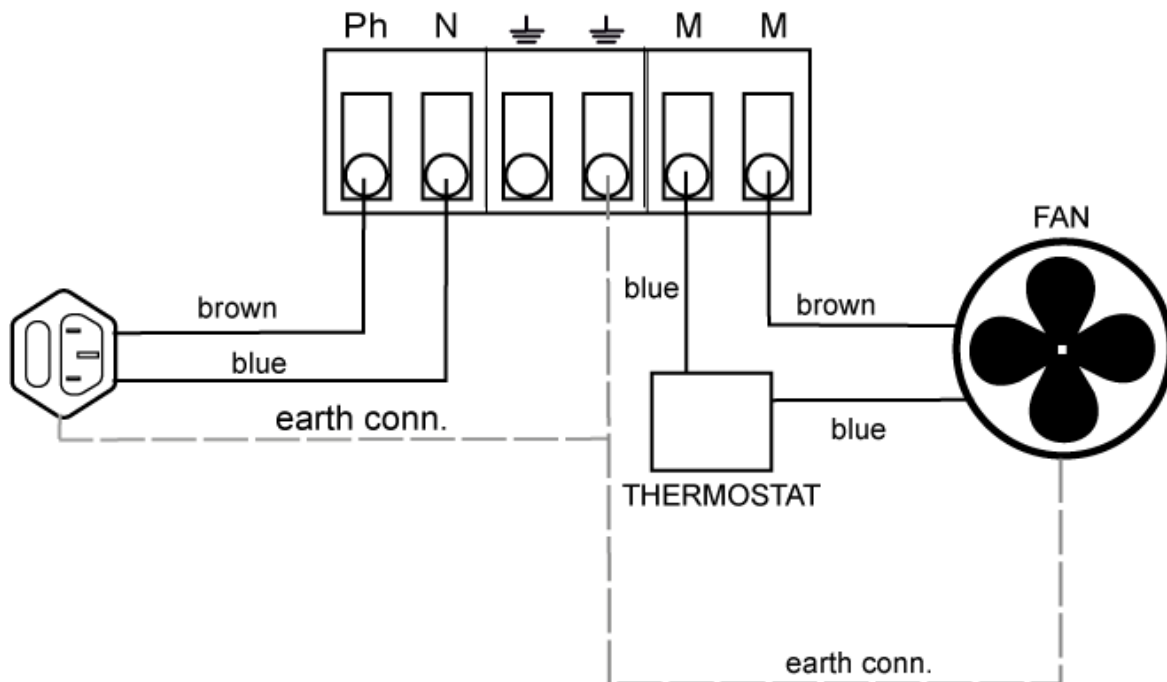

3 FUEL

3.1 General notes

This stove is designed to burn only wood logs with the following characteristics

Maximum length:	< a 30 cm
Maximum circumference	35 cm
Humidity rate:	< 20 %

We recommend to use beech, olm or in any case class A1 wood in accordance with UNI EN ISO 17225-5. The wood should be stored in a dry and sheltered place. Damp wood is more difficult to light. Furthermore, as the temperature drops, the water tends to form condensation in the combustion chamber and in the chimney, causing a deposit of soot with the risk of fire.

CAUTION: Fresh wood is not suitable for burning in this stove, before using it, it should be stored in a dry and ventilated place.

CAUTION: The following cannot be burned on this product: coal, panels, damp wood or wood treated with paint, plastic material and trash in general.

CAUTION: The use of compressed wood logs could cause the stove to overheat due to their high calorific value.

THE USE OF POOR-QUALITY WOOD LOGS NOT IN ACCORDANCE WITH MANUFACTURER'S INSTRUCTIONS NOT ONLY DAMAGE THE STOVE AND COMPROMISE PERFORMANCE BUT MAY RESULT IN FORFEITURE OF THE WARRANTY AND COMPANY LIABILITY.

4 ASSEMBLY

4.1 General notes

Here are some general recommendations to follow in order to prevent accidents or damage to the product:

- Unpacking and installation must be performed by at least two people.
- **All handling operations must be carried out using appropriate means and in full compliance with safety regulations.**
- The positioning of the packed product must be maintained in accordance with the guidelines supplied by pictograms and written on the packaging.
- If using ropes, straps, chains, etc., make sure they are suitable for the weight to be unloaded and are in good condition.
- When moving the package, move with slow and continuous movements to avoid tearing ropes, chains, etc.
- Do not tilt excessively in order to avoid overturning.
- Do not stand within range of the loading/unloading means (forklifts, cranes, etc.).

4.2 Unpacking

Unpack the product being careful not to damage or scratch it. Remove the accessory package and any pieces of polystyrene or cardboard used to block removable parts, etc. from the stove furnace.

Take out the envelope with the user manual and the guarantee usually placed either in the combustion chamber or in the pellet tank.

Also remember not to leave packaging components (plastic bags, polystyrene, etc.) within the reach of children, as they could be potential sources of danger. Dispose of them according to regulations.

CAUTION: Ensure that the plug for the electrical connection remains accessible after stove installation.

5 USE

- All local regulations, including those relating to national and European regulations, must be observed when installing the unit. Improper installation or use of the device can result in forfeiture of the warranty.
- Do not use the unit as an incinerator or in any other way other than that for which it was designed.
- **No other fuel besides wood logs must be used. Do not use liquid fuels.**
- **The device, especially the external surfaces, gets very hot to the touch when in use. Handle with care to avoid burns.**
- Do not make any unauthorised modifications to the device. **Only use original replacement parts recommended by the manufacturer.**
- Make sure that the room where the stove is to be installed offers sufficient ventilation (see section "1.6 External air intake vent").
- Periodically check (or have someone check) the cleanliness of exhaust fumes.
- **CAUTION:** keep all flammable products well away from the stove when it operating (MINIMUM: 100 cm from the front wall).
- **CAUTION:** to prevent the escape of fumes, the combustion chamber must be kept closed except during cleaning operations, to be carried out with the stove off.
- **CAUTION:** removing the safety guard inside the tank is strictly prohibited.
- **CAUTION:** in case of pellet resupply with stove on, make sure that the pellet has not ended and the flame is always present in the brazier. If the flame is extinguished a dense white smoke may form, able to cause an explosion in the combustion chamber. The explosion can be of such intensity as to break the glass of the fire door. Therefore, pay attention to never stay in front of the stove during ignition stage if the fuel releases a dense smoke. The stove is however equipped with all safety systems required to minimize the glass breakage risk.
- **CAUTION:** prevent the fuel bag to come into contact with hot surfaces.
- **CAUTION:** remove any residue of unburned pellets caused by failed ignitions before you start the stove again.
- **CAUTION:** if during the ignition phase, the stove does not start and you notice a lot of smoke in the combustion chamber, immediately turn off the stove and replace pellets in use, as these may be too high in moisture. **Forcing ignition could make your stove a hazard.**
- **CAUTION:** if during cleaning, you find traces of spongy or hard (though not ash) pellets, replace the pellets being used as this residue may come from scraps of low-quality sawdust not usable in this type of stove. Forcing ignition can cause a fire or strong production of fumes in the chimney.
- **CAUTION:** monitor proper combustion of the pellets in the brazier. **If you should detect accumulations of unburned pellets, IMMEDIATELY TURN OFF the stove and contact the service centre.**
- **CAUTION:** When starting the stove for the first time, load the combustion chamber with only half the fuel indicated in this manual and keep the product on for at least 6 hours continuously. Then load the combustion chamber with an increasingly greater quantity of fuel until you reach a complete charge after 4 or 5 ignitions.
- **CAUTION:** Never overload the appliance. Too much wood can overheat and therefore damage the stove. The warranty does not cover damage due to overheating of the appliance.
- **CAUTION:** exercise extreme caution in the presence of children, to prevent them from standing in front of the stove.

5.1 Ignition

- 1 Place the starter lever in the open position (fig 15)
- 2 Position the air register to its maximum position (fig.16) and keep any butterfly valve located on the fume exhaust pipe open to the maximum position
- 3 Place small wooden strips in the combustion chamber, place a solid or gel lighter or igniter on top of the strips and light with flame burners
- 4 Leave the door closed for a couple of minutes or more (this depends on the temperature of the house and the flue). Close the door only when the flame reaches a minimum height of approximately 7 cm, so as to touch the holes on the rear wall. . At this point the stove is lit and the incoming air and the butterfly valve on the flue can be adjusted in order to obtain the desired combustion.

The fire door is equipped with a return spring which makes it close automatically.

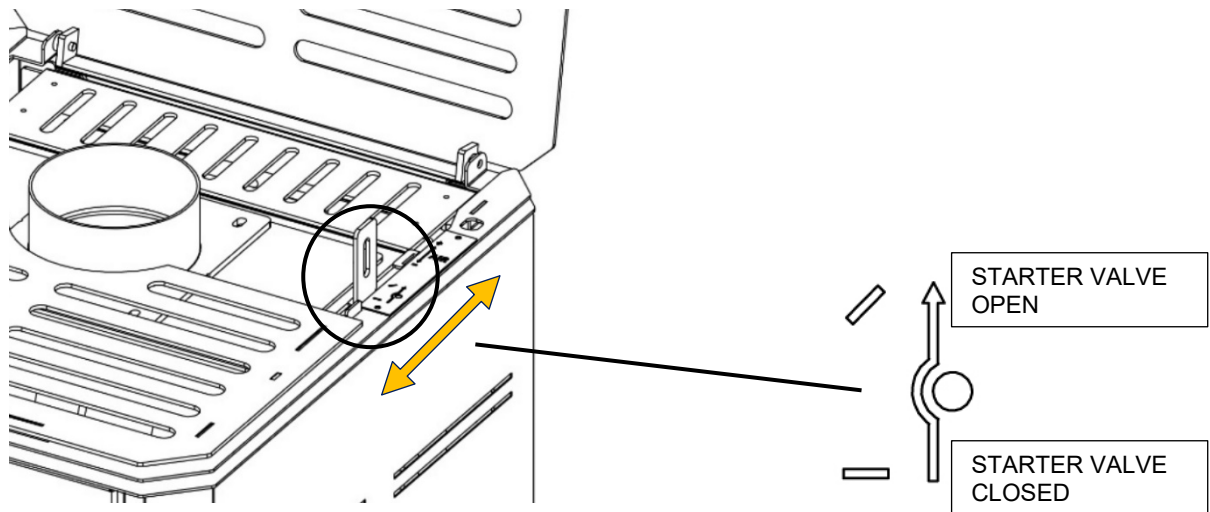

Fig. 15

5.2 Normal operation

Once the ignition phase has been completed, insert the hourly wood load indicated in this manual into the appliance.

This stove must operate, except during the lighting and loading phases, with the fire door closed to prevent fumes from escaping.

Leaving the door open or ajar during normal operation of the stove would allow excessive air to enter the firebox with penalization of combustion efficiency.

CAUTION: Avoid overloading the combustion chamber and always leave free space between the logs and the door.

Failure to comply with these rules could lead to malfunctions or damage to the paint on the doors

The flow of combustion air into the stove is regulated by a thermostatic valve which closes automatically when the water temperature rises above a certain threshold.

CAUTION: Avoid putting out the fire with water: violent thermal stress could seriously damage the stability of some parts of the stove and of the refractory at the base of the firebox.

5.3 Ventilation (only suitable models)

In ventilated models, a fan can be activated which allows you to accelerate the diffusion of heat in the room or to heat another room via rear ducting

5.3.1 Control panel

Using the control panel located at the rear of the stove it is possible to manually turn the ventilation on and off and adjust the speed of the fan

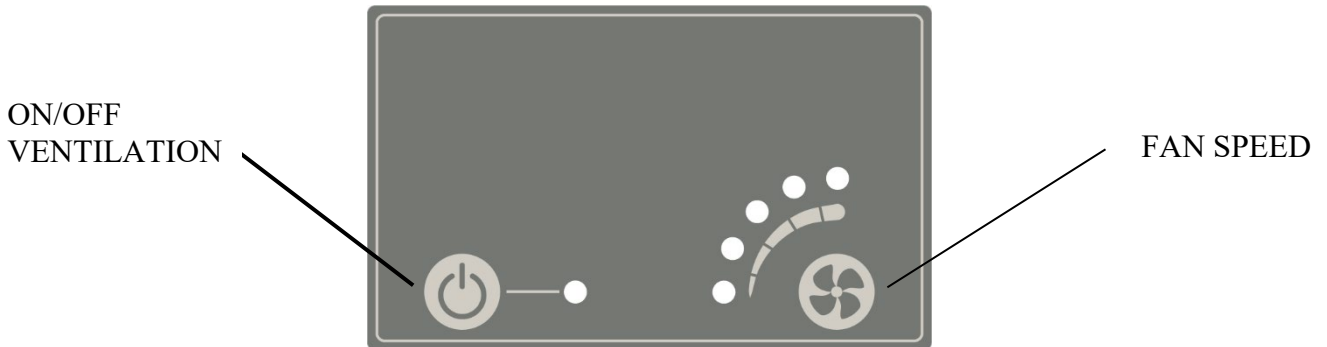



Fig. 17

Console button functions

	<i>ON/OFF</i>	Function: <ul style="list-style-type: none"> • Turning the ventilation On and Off
	<i>VENTILATION SPEED</i>	Function: <ul style="list-style-type: none"> • Regulation of ventilation speed in one of the 5 available levels

5.3.2 Ventilated air distribution

Using a manual lever it is possible too choose whether to send the hot ventilated air into the room where the stove is installed or to channel it into another room

To make the choice follow the instructions in the figure below

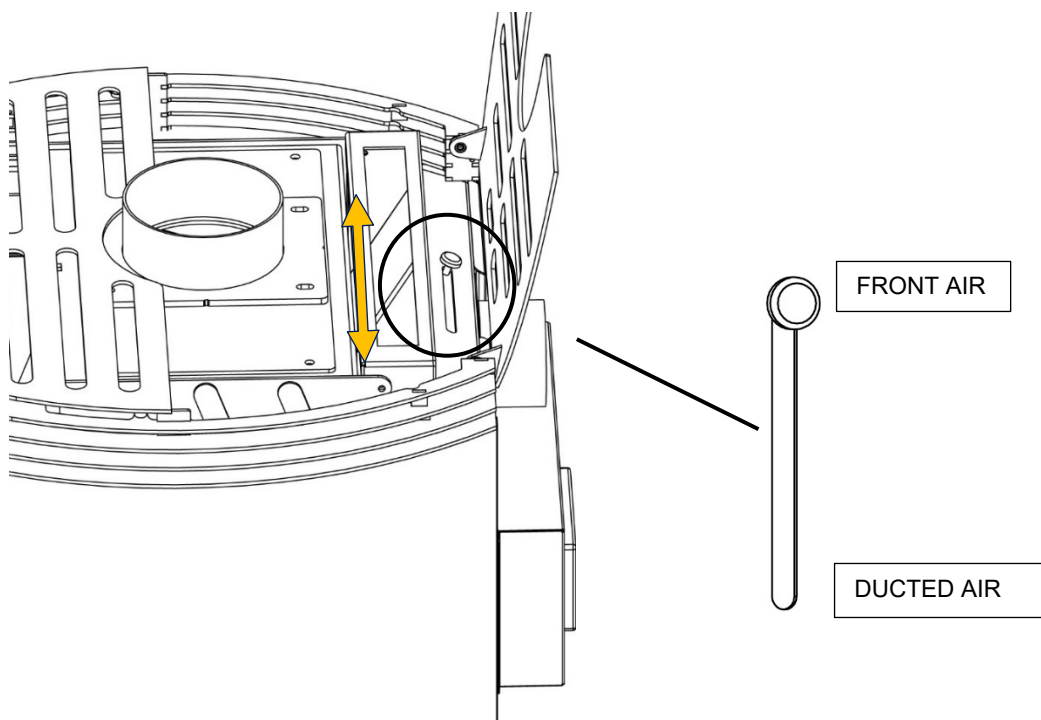

Fig. 18

6 WARNING AND MAINTENANCE

CAUTION: During operation, some parts of the stove (door, handle, ceramic pieces) can reach high temperatures, always use the glove supplied

Remember to maintain the previously indicated safety distances.

Therefore, be very careful, use the necessary precautions and always follow the instructions.

If during operation any part of the stove or the outlet pipe leaks smoke, immediately turn off the stove and ventilate the room. Then once it has cooled down, check the reason for the leak and if necessary call specialized technical personnel.

All maintenance operations (cleaning, replacements, etc.) should be carried out when the fire is out and the stove is cold. In addition, do not use any abrasive substances.

CAUTION: FAILURE TO CLEAN AFFECTS SAFETY

6.1 *Opening the door*

The door must remain closed during operation.

The door should only be opened to load fuel and to carry out routine maintenance and cleaning.

6.2 *Combustion chamber cleaning*

Clean the combustion chamber weekly, removing ashes accumulated in the chamber using a vacuum cleaner.

Note Use a vacuum cleaner designed for the suction of ashes for this type of cleaning.

6.3 *Smoke chamber cleaning*

Generally, clean the smoke chamber once a year (preferably at the beginning of the season) for best stove operation. The frequency of this operation depends on the type of pellet used and the frequency of use.

Contact a Technical Assistance Centre for this type of cleaning.

6.4 *Exhaust system cleaning*

Until you are reasonably experienced regarding operating conditions, it is advisable to perform this service at least monthly. Remove the T-fitting cap and proceed with duct cleaning.

If necessary, at least the first few times, request assistance from a qualified technician.

6.5 *Cleaning metal and ceramic parts*

Use a soft cloth moistened with water to clean metal stove parts.

Never clean metal or ceramic parts with alcohol, thinners, petrol, ketones or other degreasers.

Use of these substances frees the company from all liability. Discolouration of metal parts can be the result of improper use of the stove

6.6 *Cleaning glass*

Door glass must be clean cold with ammonia-based and non-corrosive degreasers as a diluent. Prevent corrosive substances from coming into contact with the paint on the stove as these can cause damage. If glass is hot, before proceeding with cleaning, keep the door open as long as necessary until it cools down. Do not use any material that can scratch or damage the glass.

6.7 *Broken glass*

The stove is equipped with 5 mm thick ceramic glass that is resistant to a thermal shock of 750°C. This glass can break only due to a strong impact or misuse. Do not slam the door or hit the glass. In case of breakage, replace with an original replacement part only.

Contact a Technical Assistance Centre to replace.

arts, have the fan cleaned by Technical Assistance Centre or qualified personnel only.

6.8 Stove inactivity

At the end of the season, perform the following operations:

- Thoroughly clean the combustion chamber
- Thoroughly clean the smoke exhaust system: contact a professional chimney sweep for this purpose.
- Clean all dust, spider webs, etc. from the area behind the panels of the inner cladding once a year.
- Clean fans thoroughly.
- Leave the fire door ajar to prevent the humidity entering from the smoke duct from oxidizing the internal walls.

6.9 Routine and special maintenance

These operations should be programmed **annually** with a Technical Assistance Centre and are necessary to ensure the maintenance of product efficiency and ensure safe operation.

- Thoroughly clean the combustion chamber and the heat exchanger.
- cleaning of the smoke exhaust duct, new silicone where required.
- Inspection and verification of seals, replacement and silicone application where required.
- Check and replacement, if necessary, of components that are subject to wear



Dasa-R&gister
EN ISO 9001 (2000)
IQ-0502-09

Laminox S.r.l.
Zona Industriale Callarella, 261/263 – 62028 SARNANO (MC) Italy
Tel. +39 0733.657.622 – Fax +39 0733.657.494
www.laminox.com e-mail: export@laminox.com